

NOTES:

1. TO INSPECT ASSEMBLY, FOLLOW FIRST ARTICLE AND IN PROCESS INSPECTION SHEET.

BILL OF MATERIAL (CURRENT LEVEL)

ITEM	PT/ASSY	DESCRIPTION	TYPE	QTY.
1	3-640	W/M LAVATORY SPOUT W/ESC.	ASSEMBLY	1
2	3-648	LEVER HANDLE W/ESC.	ASSEMBLY	2

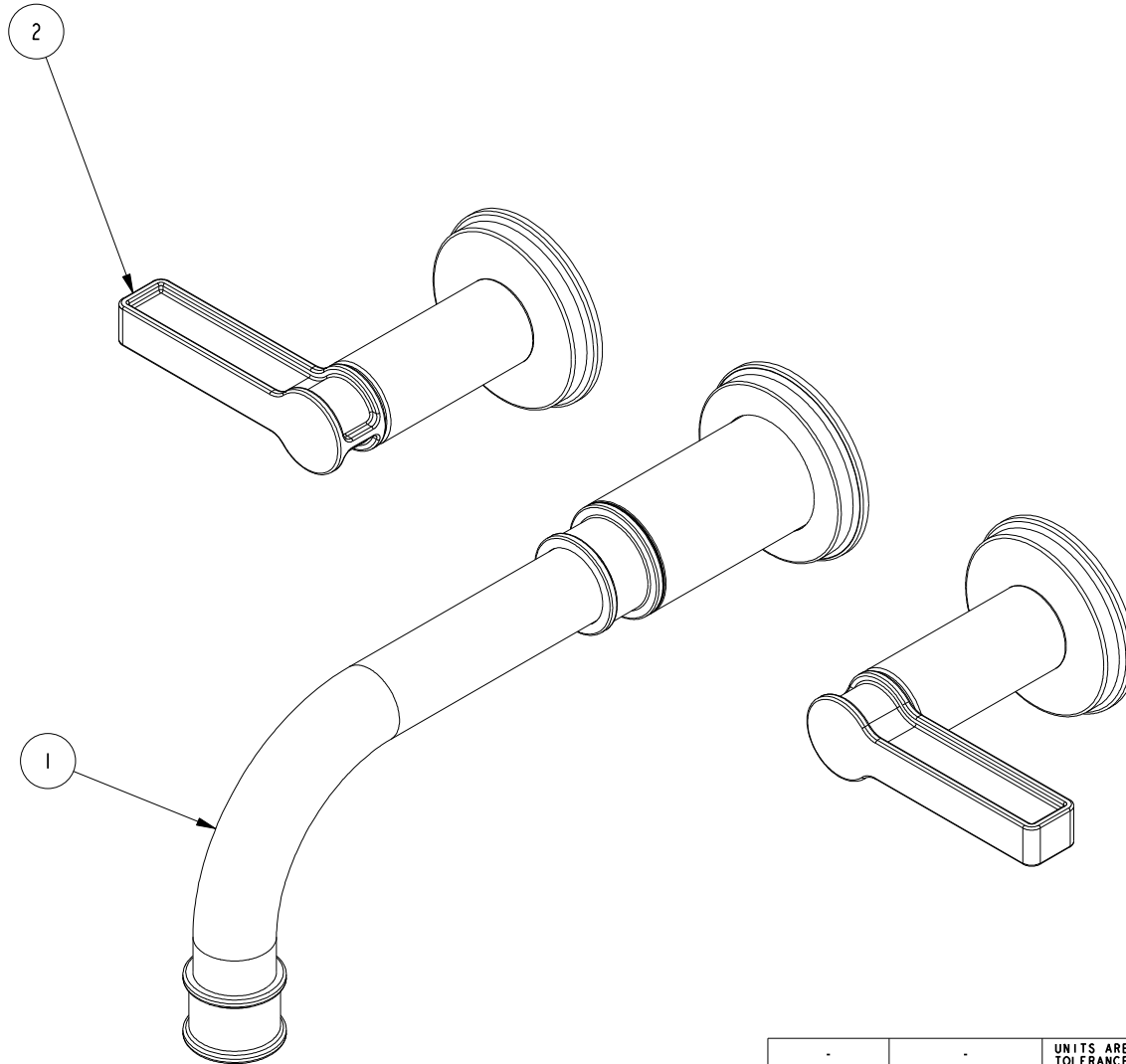

ZONE	REV	DESCRIPTION	DATE	APPROVED
-	A	EN-3961-2	05/28/20	J.M.
-	-	EN-3478	01/16/19	J.M.

COPYRIGHT 2005 BRASSTECH, INC. THESE DRAWINGS AND THE DESIGNS DEPICTED HEREIN ARE THE PROPRIETARY PROPERTY OF BRASSTECH. ANY USE OR REPRODUCTION IS SUBJECT TO THE EXPRESS APPROVAL OF BRASSTECH. UNAUTHORIZED USE IS STRICTLY PROHIBITED. ALL RIGHTS RESERVED.

TESTING	-	-	-
ASSEMBLY	-	-	-
PLATING	-	-	-
POLISHING	-	NEXT ASSY	USED ON
MACHINING	-	APPLICATION	
TOOLING FIXTURE #	REMOVE ALL BURRS AND SHARP EDGES		

UNITS ARE: INCHES [MM]		
TOLERANCES ARE:		
FRACTIONS	DECIMALS	ANGLES
±1/16"	.X ±.1 [2.5]	±1°
	.XX ±.06 [1.5]	
(X.XXX) DENOTES CRITICAL DIMS.		
ALL THREADS ARE CRITICAL		
DRAWN	JIMSON	01/16/19
CHECKED	J.M.	01/16/19
APPROVED	J.M.	01/16/19

BRASSTECH 2001 CARNEGIE AVE. SANTA ANA, CA 92705 (949) 417-5207
INCORPORATED

WALL MOUNT LAV FAUCET

DWG NO.	3-3271	REV	A
SCALE	.500	REF.	-
SHEET	1	OF	3

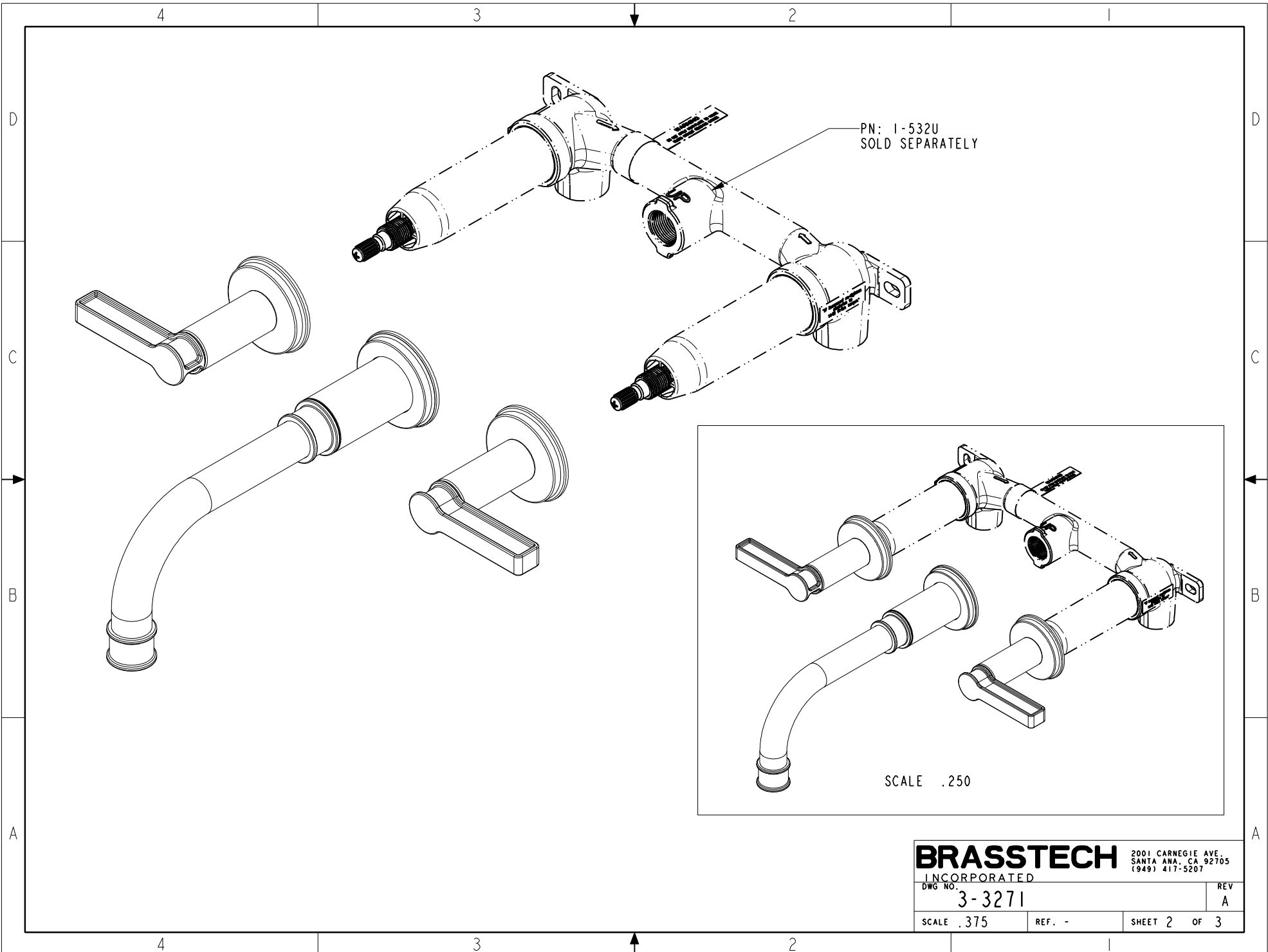

PN: 1-532U
SOLD SEPARATELY

SCALE .250

BRASSTECH		2001 CARNEGIE AVE. SANTA ANA, CA 92705 (949) 417-5207	
INCORPORATED			
DWG NO.	3-3271	REV	A
SCALE .375	REF. -	SHEET 2	OF 3

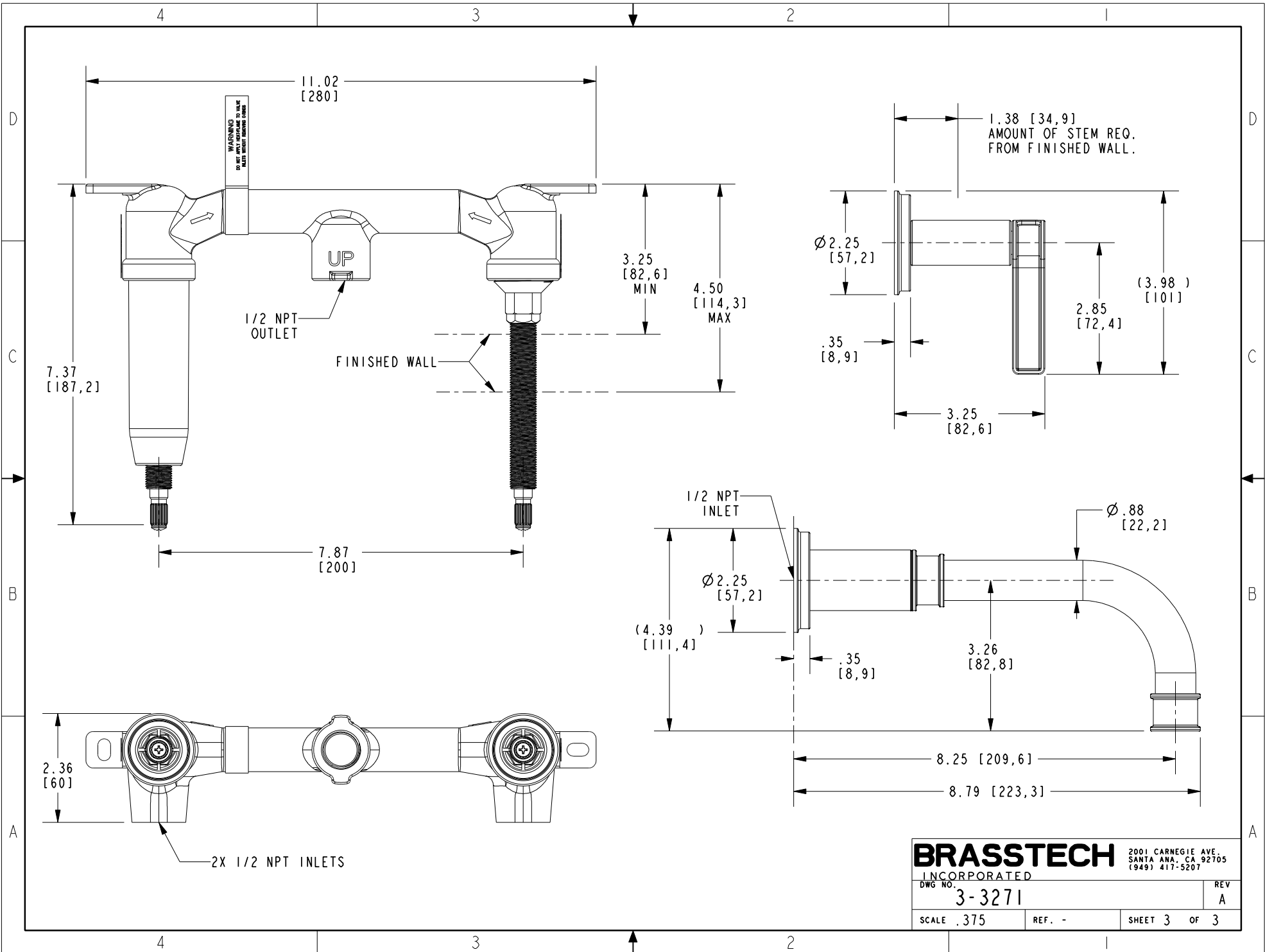

BRASSTECH
 INCORPORATED
 2001 CARNEGIE AVE.
 SANTA ANA, CA 92705
 (949) 417-5207

DWG NO. 3-3271	REV A
SCALE .375	REF. -
SHEET 3	OF 3