

**PL1402-3**

**PULSAR**

**WATER SAVER FLUSH VALVE**  
*( 3.5gpf / 13.2Lpf Per Flush )*

**B**attery Powered, Sensor Operated, polished chrome plated flush valve, diaphragm type, equipped with Pulsar Sensor Module for ADA compliant "Hands Free" operation includes ABS hard plastic cover with sensor electronics, solenoid valve, one (1) dual-cell lithium battery with 10 year shelf life, and over-ride button. Sensor electronics are range adjustable with low battery indicator LED, and optional 24 hr. "Cleanser Flush". Supplied with 1" capped screwdriver angle stop with back-check, sweat adapter kit, renewable main valve seat, "Turn-to-Silence" quiet equipment, with "KwikFit" threaded union tailpiece, vacuum breaker, wall flange, spud nut and flange for 1-1/2" top spud.

**Variations**

- G – Bumper on angle stop
- T6 – Heavy wall flange with allen set screw
- T106 – Mashaerator self cleaning by pass diaphragm

**Remarks**

**\* For use with 3.5 gallon water saver water closet**

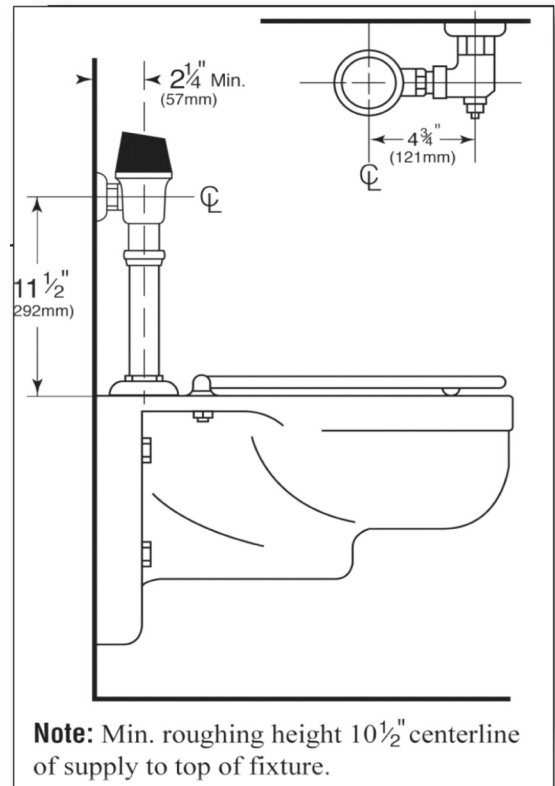

P.O. Box 411 · Charlottesville · VA · 22902 · USA  
Phone: (434) 296-0166 · Fax (434) 977-3596  
Email: info@delanyproducts.com  
Web: www.delanyproducts.com  
©2013

