

PL1402-1.6

PULSAR

*LOW CONSUMPTION FLUSH VALVE
(1.6gpf / 6.0Lpf Per Flush)*

Battery Powered, Sensor Operated, polished chrome plated flush valve, diaphragm type, equipped with Pulsar Sensor Module for ADA compliant "Hands Free" operation includes ABS hard plastic cover with sensor electronics, solenoid valve, one (1) dual-cell lithium battery with 10 year shelf life, and over-ride button. Sensor electronics are range adjustable with low battery indicator LED, and optional 24 hr. "Cleanser Flush". Supplied with 1" capped screwdriver angle stop with back-check, sweat adapter kit, renewable main valve seat, "Turn-to-Silence" quiet equipment, with "KwikFit" threaded union tailpiece, vacuum breaker, wall flange, spud nut and flange for 1-1/2" top spud.

Variations

- G – Bumper on angle stop
- T6 – Heavy wall flange with allen set screw
- T106 – Mashaerator self cleaning bypass diaphragm

Remarks

** For use with 1.6 gallon low consumption water closet*

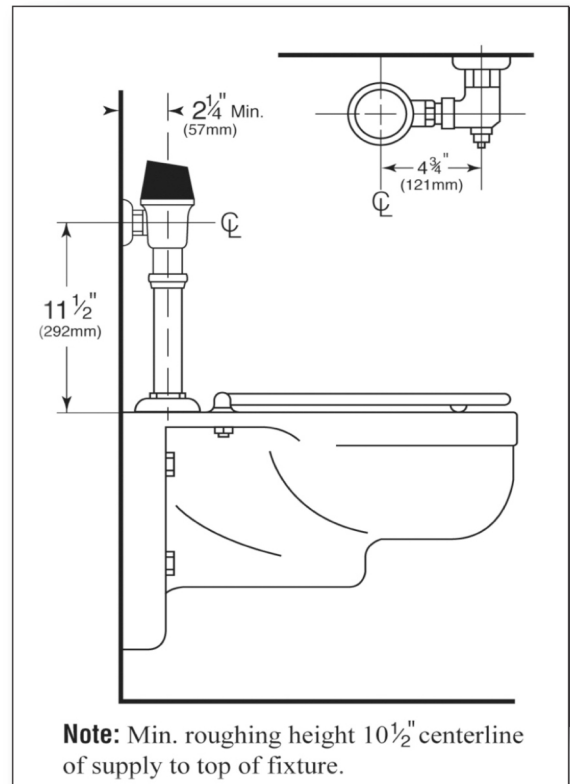

P.O. Box 411 · Charlottesville · VA · 22902 · USA
Phone: (434) 296-0166 · Fax (434) 977-3596
Email: info@delanyproducts.com
Web: www.delanyproducts.com
©2013

