

Trade Mark:  
CRYSTAL WORLD INC

Product Name: Pendant lamp  
Model :5625W5ST  
120Vac, 60Hz,AC ONLY  
Lamp Size:5"\*H4"\*E7"

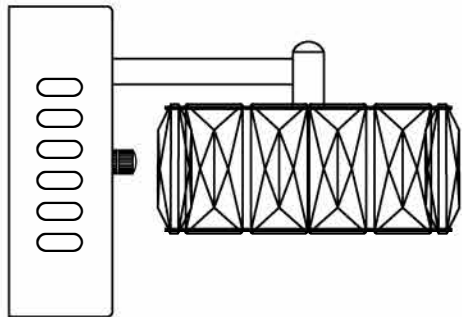

## PENDANT LAMP ASSEMBLY INSTRUCTIONS

1. Install bulbs( NOT INCLUDED).USE **120V LED**  **5W\*1PCS (4000K)**
2. Dimmable

