



HydroLink™ hydraulic separator-manifold

5599 series



01084/14 NA

Replaces 01084/05 NA



Function

The HydroLink™ is a device combining a hydraulic separator and distribution manifold header used in heating systems. This device provides uniform supply water temperature to distribution circuits when there is one boiler or multiple boilers. The HydroLink™ offers easy, labor-saving installation in any type of hydronic circuit by combining hydraulic separation with a prefabricated distribution manifold into a single compact unit.

The HydroLink™ 5599 series is compatible with HydroMixer™ 165, 166, 167 series mixing units.

Product range

- Code 559920A Hydraulic separator-manifold 2+0 with insulation and built-in mountingconnections 1" FNPT main + 1" MNPT branches
- Code 559921A Hydraulic separator-manifold 2+1 with insulation and built-in mountingconnections 1" FNPT main + 1" MNPT branches
- Code 559922A Hydraulic separator-manifold 2+2 with insulation and angle mounting brackets
.....connections 1¼" FNPT main + 1" MNPT branches
- Code 559931A Hydraulic separator-manifold 3+1 with insulation and angle mounting brackets
.....connections 1¼" FNPT main + 1" MNPT branches

Technical specifications

Materials

Body: painted steel
 Maximum working pressure: 100 psi
 Working temperature range: 32 to 230°F (0 to 110°C)

Performance

Suitable Fluids: water, glycol solutions
 Max. percentage of glycol: 50%

Connections

Main connections: 2+0 and 2+1: 1" NPT female
 2+2 and 3+1: 1 ¼" NPT female
 Outlet branches: 2+0 and 2+1: 1" NPT male
 2+2 and 3+1: 1" NPT male
 Air vent: ½" NPT female
 Drain valve: ½" NPT female

Center distances

Main connections: 2+0 and 2+1: 60 mm (2-3/8")
 2+2 and 3+1: 80 mm (3-1/8")
 Outlet branches: 2+0 and 2+1: 125 mm (4-15/16")
 2+2 and 3+1: 125 mm (4-15/16")

Insulation

Material: EPP
 Thickness: ¾" (20 mm)
 Density: 3 lb/ft³ (45 kg/m³)
 Thermal conductivity:
 - at 50°F (10°C): 0.256 BTU-in/hr-ft²·°F (0.037 W/(m·K))
 Fire resistance (UL 94): class HBF

Flow characteristics

Maximum recommended flow rate at connections:

Outlet Branches	Primary	Secondary (total)
2+0	9 gpm (0.5 l/s)	22 gpm (1.5 l/s)
2+1	9 gpm (0.5 l/s)	22 gpm (1.5 l/s)
2+2	11 gpm (0.7 l/s)	26 gpm (1.7 l/s)
3+1	11 gpm (0.7 l/s)	26 gpm (1.7 l/s)

Dimensions

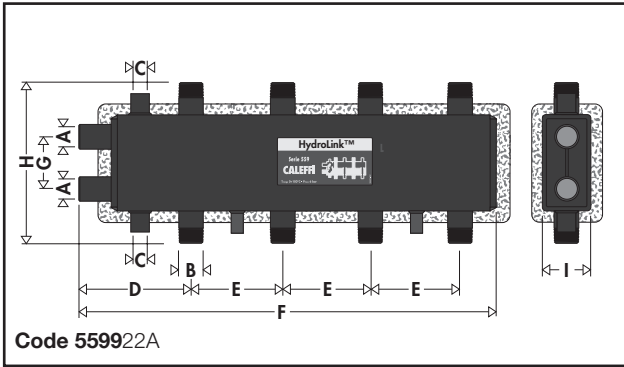

A	B	C	D	E	F	G	H	I
1 1/4"	1"	1/2"	7-1/16"	4-15/16"	23-13/16"	3-1/8"	11-13/16"	3-1/8"

Weight (lb)	29
Volume (gal)	2

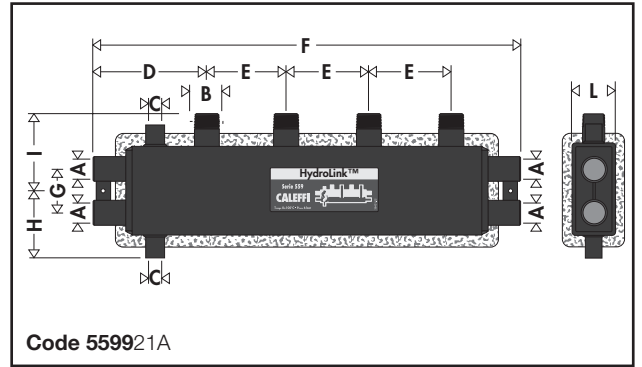

A	B	C	D	E	F	G	H	I	L
1"	1"	1/2"	7-1/16"	4-15/16"	25-3/4"	2-3/8"	3-9/16"	4 1/4"	2-3/8"

Weight (lb)	16
Volume (gal)	1

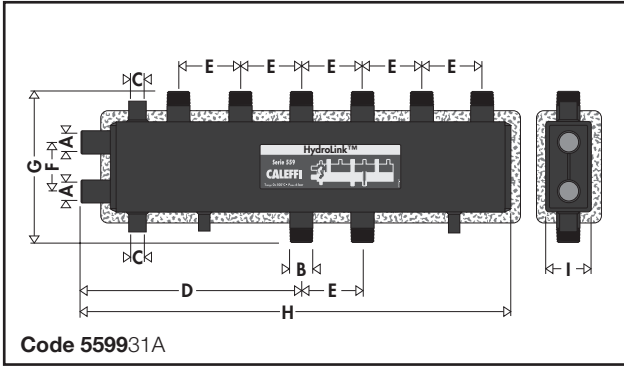

A	B	C	D	E	F	G	H	I
1 1/4"	1"	1/2"	16-15/16"	4-15/16"	3-1/8"	10"	33-11/16"	3-1/8"

Weight (lb)	39
Volume (gal)	2.8

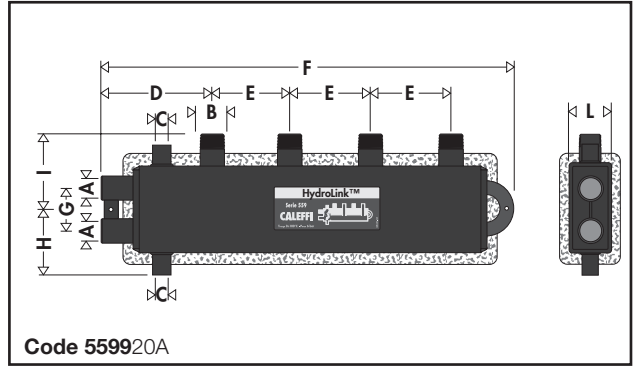

A	B	C	D	E	F	G	H	I	L
1"	1"	1/2"	7-1/16"	4-15/16"	25-9/16"	2-3/8"	3-9/16"	4 1/4"	2-3/8"

Weight (lb)	16
Volume (gal)	1

Operating principle

When a system contains a primary boiler circuit with its own pump and a secondary distribution circuit with one or more distribution pumps, operating conditions may arise in the system where the pumps interact. This can create abnormal variations in flow rates and pressures in the circuits.

The HydroLink™ provides a separation chamber on the left side of the unit to hydraulically separate the boiler circuit from the distribution circuits: **the flow in one circuit does not create a flow in the other if the pressure loss in the common section is negligible.**

This chamber is separated from the manifold chambers by a baffle plate with two closely spaced openings which, given their size and placement, act similarly to a pair of closely spaced tees. This eliminates any significant pressure differential between the upper and lower manifold chambers that comprise a self-contained manifold station with up to four independently controlled load circuits delivering the same supply temperature.

Three possible hydronic balance situations are shown below as examples.

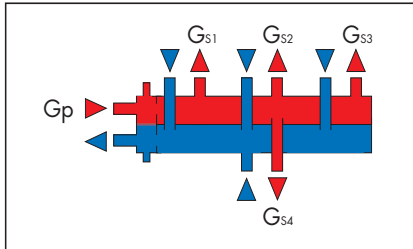
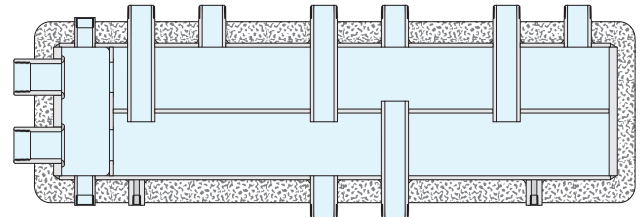
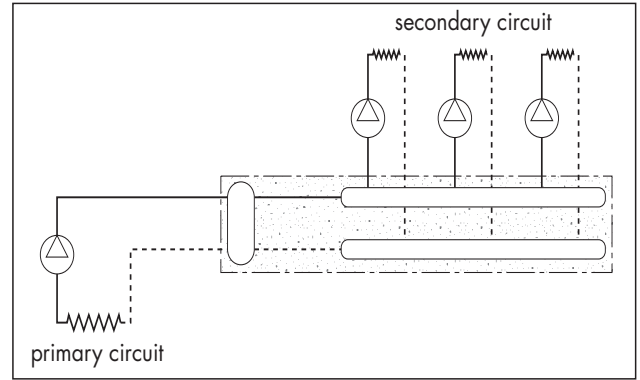

$$G_{\text{primary}} = G_{\text{secondary}} (G_{s1} + G_{s2} + G_{s3} + G_{s4})$$

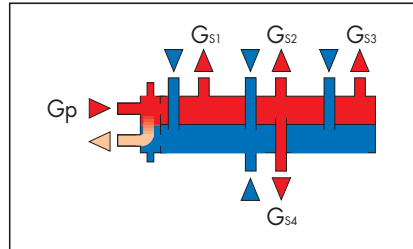

$$G_{\text{primary}} > G_{\text{secondary}} (G_{s1} + G_{s2} + G_{s3} + G_{s4})$$

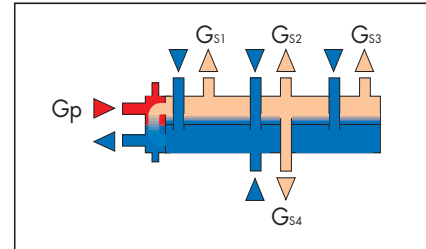

$$G_{\text{primary}} < G_{\text{secondary}} (G_{s1} + G_{s2} + G_{s3} + G_{s4})$$

Installation

HydroLink™ units should be installed in accordance with the diagrams shown in this brochure, ensuring the correct connection of the supply and return piping and the main (primary) and branch (secondary) connections. HydroLink™ units can even be installed upside down as long as the connection logic shown is followed and the air vent and drain valve are swapped.

The 1/2" NPT female connections must only be used for connecting an air vent and drain valve (provided with the HydroLink™ assembly) and not for connecting branch circuits.

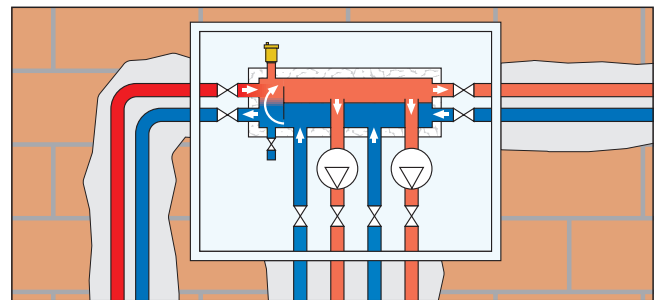
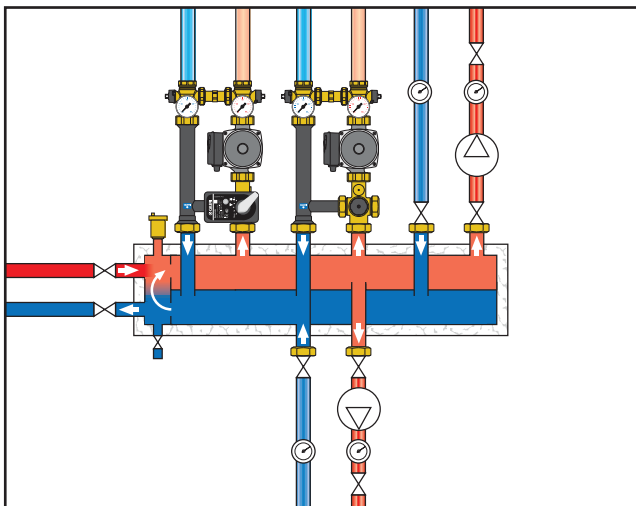

Insulation

The HydroLink™ is supplied with heat-preformed shell insulation. This provides heat insulation and a sealing affect that prevents atmospheric water vapor from entering the unit. For this reason, the insulated HydroLink™ assembly may also be used in cooling water circuits, as it prevents condensation from forming on the surface of the body.

Support brackets

The HydroLink™ 2+2 and 3+1 models are supplied complete with suitable wall-mounting brackets, making it easy to adjust for front-to-back positioning.

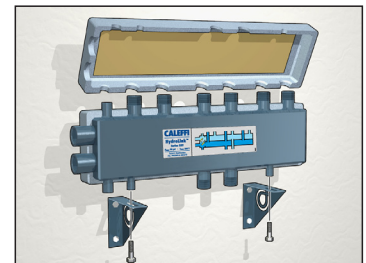

Application Diagrams

System with wall-mounted boiler, angle mounting HydroLink™ 2+2, and HydroMixers™.

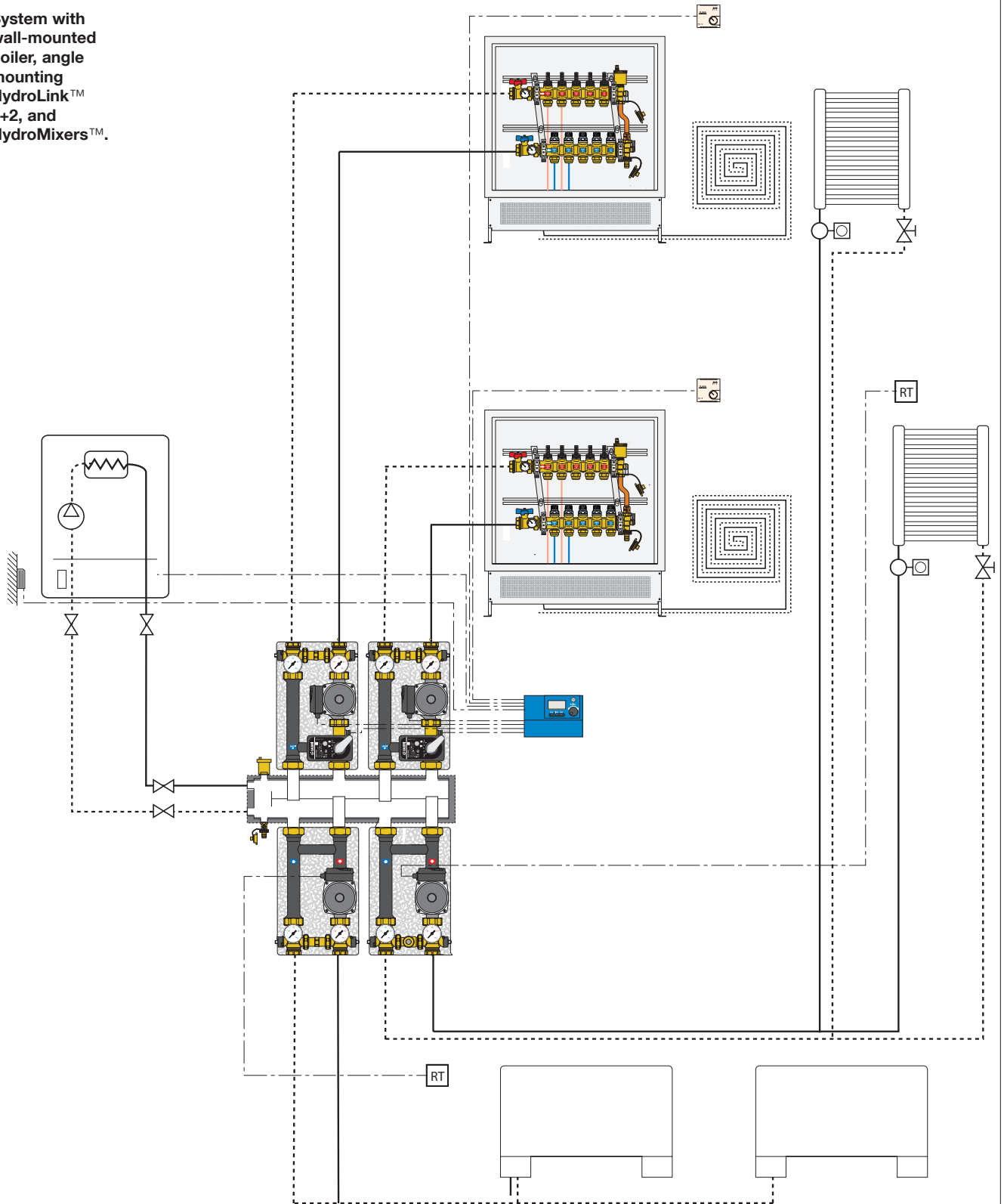

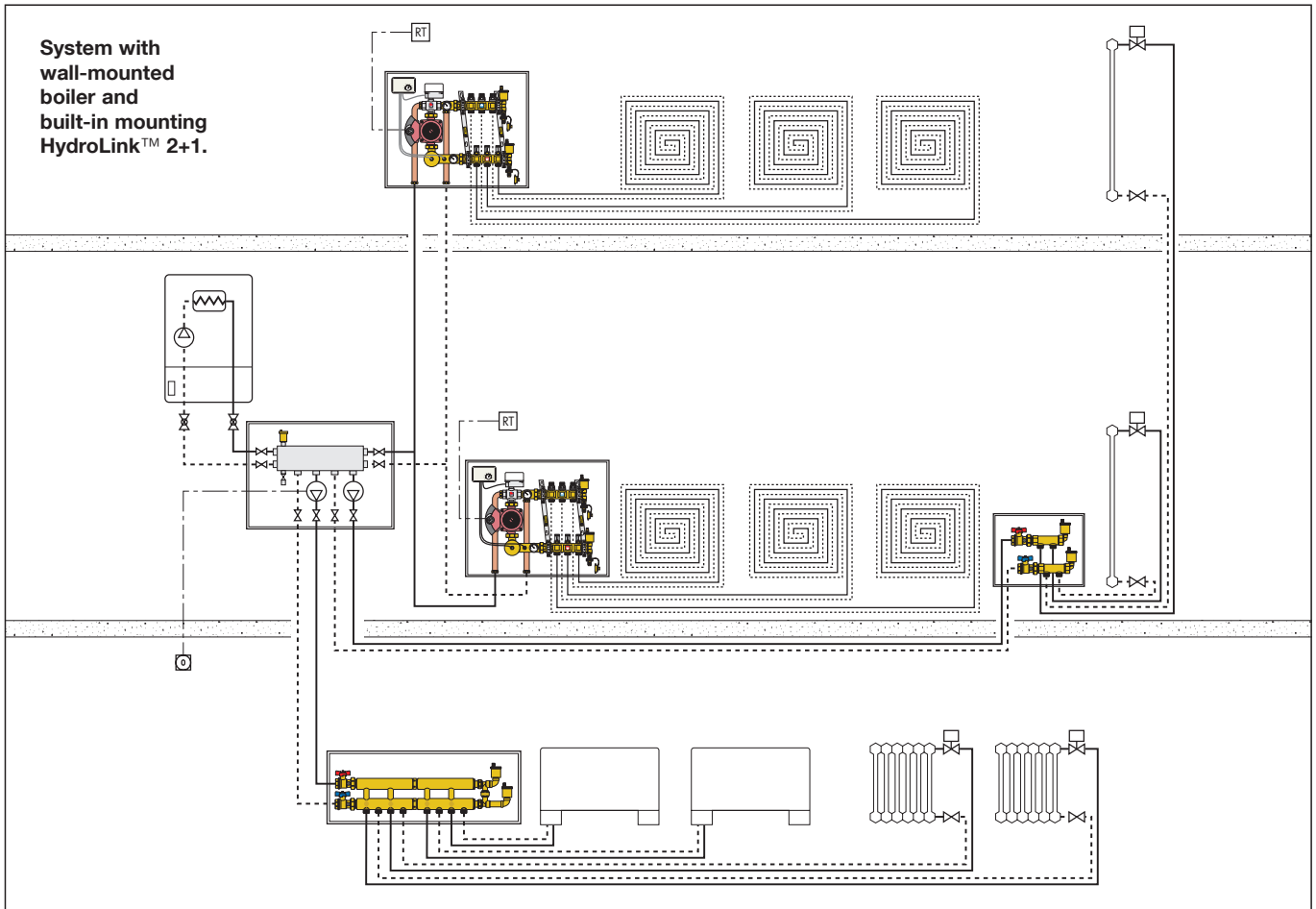

SPECIFICATION SUMMARY

Code 559920A

HydroLink™ hydraulic separator plus distribution manifold header with built-in wall mounting, branches 2+0, for heating systems. Painted steel body with pre-formed insulation. Main connections (to primary) 1 inch NPT female, center distance 2-3/8 inch (60 mm); connections to branches (secondary) 1 inch NPT male, center distance 4-15/16 inch (125 mm). 1/2 inch NPT female connections for air vent and drain valve. Maximum working pressure 100 psi. Working temperature range 32 to 230 degrees F (0 to 110 degrees C). Suitable fluids: water or 50 percent maximum glycol solution. Max. flow rate: 9 gpm (0.5 l/s) primary, 22 gpm (1.5 l/s) secondary (total all branches). Provided with air vent and drain valve.

Code 559921A

HydroLink™ hydraulic separator plus distribution manifold header with built-in wall mounting, branches 2+1, for heating systems. Painted steel body with pre-formed insulation. Main connections (to primary) 1 inch NPT female, center distance 2-3/8 inch (60 mm); connections to branches (secondary) 1 inch NPT male, center distance 4-15/16 inch (125 mm). 1/2 inch NPT female connections for air vent and drain valve. Maximum working pressure 100 psi. Working temperature range 32 to 230 degrees F (0 to 110 degrees C). Suitable fluids: water or 50 percent maximum glycol solution. Max. flow rate: 9 gpm (0.5 l/s) primary, 22 gpm (1.5 l/s) secondary (total all branches). Provided with air vent and drain valve.

Code 559922A

HydroLink™ hydraulic separator plus distribution manifold header complete with angle mounting brackets, branches 2+2, for heating systems. Painted steel body with pre-formed insulation. Main connections (to primary) 1-1/4 inch NPT female, center distance 3-1/8 inch (80 mm); connections to branches (secondary) 1 inch NPT male, center distance 4-15/16 inch (125 mm). 1/2 inch NPT female connections for air vent and drain valve. Maximum working pressure 100 psi. Working temperature range 32 to 230 degrees F (0 to 110 degrees C). Suitable fluids: water or 50 percent maximum glycol solution. Max. flow rate: 11 gpm (0.7 l/s) primary, 26 gpm (1.7 l/s) secondary (total all branches). Provided with air vent and drain valve.

Code 559931A

HydroLink™ hydraulic separator plus distribution manifold header complete with angle mounting brackets, branches 3+1, for heating systems. Painted steel body with pre-formed insulation. Main connections (to primary) 1-1/4 inch NPT female, center distance 3-1/8 inch (80 mm); connections to branches (secondary) 1 inch NPT male, center distance 4-15/16 inch (125 mm). 1/2 inch NPT female connections for air vent and drain valve. Maximum working pressure 100 psi. Working temperature range 32 to 230 degrees F (0 to 110 degrees C). Suitable fluids: water or 50 percent maximum glycol solution. Max. flow rate: 11 gpm (0.7 l/s) primary, 26 gpm (1.7 l/s) secondary (total all branches). Provided with air vent and drain valve.

We reserve the right to change our products and their relevant technical data, contained in this publication, at any time and without prior notice.